

MST 750  
Spring 2022  
Exam #1  
02/16/22

Name (Print): key

The following rules apply:

- **If you use a “fundamental theorem” you must indicate this** and explain why the theorem may be applied.
- **Organize your work**, in a reasonably neat and coherent way, in the space provided. Work scattered all over the page without a clear ordering will receive very little credit.
- **Short answer questions:** Questions labeled as “Short Answer” can be answered by simply writing an equation or a sentence or appropriately drawing a figure. No calculations are necessary or expected for these problems.
- **Unless the question is specified as short answer, mysterious or unsupported answers might not receive full credit.** An incorrect answer supported by substantially correct calculations and explanations might still receive partial credit.

Problem	Points	Score
1	10	
2	5	
3	10	
4	10	
5	25	
6	20	
7	20	
Total:	100	

Do not write in the table to the right.

1. (10 points) Consider the following differential equation on  $\mathbb{R}$ :

$$\dot{x} = f(t)x + g(t)x^n,$$

where  $f, g : \mathbb{R} \rightarrow \mathbb{R}$  are smooth functions. Show that the transformation  $y = x^{1-n}$  yields the linear equation

$$\dot{y} = (1-n)f(t)y + (1-n)g(t).$$

If  $y = x^{1-n}$  then

$$\begin{aligned}\dot{y} &= (1-n)x^{-n}\dot{x} \\ &= (1-n)x^{-n}(f(t)x + g(t)x^n) \\ &= (1-n)f(t)x^{1-n} + g(t)\end{aligned}$$

2. (5 points) Consider the following differential equation

$$\dot{x} = Ax,$$

where  $A$  is a  $2 \times 2$  matrix. Circle any of the the following which could be solutions to this type of equation and cross out any that could not.

(a)  ~~$x(t) = (3e^t + e^{-t}, e^{2t})$~~

(b)  $x(t) = (3e^t + e^{-t}, e^t)$

(c)  ~~$x(t) = (3e^t + e^{-t}, te^t)$~~

(d)  ~~$x(t) = (3e^t, t^2e^t)$~~

(e)  ~~$x(t) = (e^t + 2e^{-t}, e^t + 2e^{-t})$~~

3. (10 points) Consider the differential equation

$$\begin{aligned}\dot{x} &= a(t)x, \\ x(0) &= x_0,\end{aligned}$$

where  $a : \mathbb{R} \mapsto \mathbb{R}$  is a smooth function.

(a) (8 points) Find an explicit formula for solutions to this equation.

$$x(t) = x_0 e^{\int_0^t a(s) ds}.$$

(b) (1 point) **True or False:** There exists a non-vanishing  $T$ -periodic solution if and only if  $\int_0^T a(s) ds = 0$ .

(c) (1 point) **True or False:** There exists an unbounded solution in  $\mathbb{R}^+$  if and only if  $\int_0^t a(s) ds \neq 0$  for some  $t > 0$ .

4. (10 points) Consider the following system of differential equations

$$\dot{x} = Ax,$$

where  $A$  is  $2 \times 2$  real matrix.

- (a) (4 points) **Short Answer:** In terms of the eigenvalues and their multiplicities, find necessary and sufficient conditions on  $A$  that guarantee solutions to this system converge to the origin.

$$\operatorname{Re}(\lambda_1, \lambda_2) < 0$$

- (b) (3 points) **Short Answer:** In terms of the eigenvalues and their multiplicities, find necessary and sufficient conditions on  $A$  that guarantee solutions to this system are bounded.

$$\operatorname{Re}(\lambda_1) = \operatorname{Re}(\lambda_2) = 0$$

The geometric and algebraic multiplicity are equal.

- (c) (3 points) **Short Answer:** In terms of the eigenvalues and their multiplicities, find necessary and sufficient conditions on  $A$  that guarantee solutions to this system are bounded for  $t > 0$ .

$$1. \operatorname{Re}(\lambda_1, \lambda_2) < 0$$

$$2. \operatorname{Re}(\lambda_1) < 0, \operatorname{Re}(\lambda_2) = 0$$

$$\operatorname{Re}(\lambda_1) = 0, \operatorname{Re}(\lambda_2) < 0$$

$$3. \operatorname{Re}(\lambda_1) = \operatorname{Re}(\lambda_2) = 0$$

The geometric and algebraic multiplicities are equal.

5. (25 points) Do either part (a) or part (b). Circle which problem you want graded.

(a) Consider the following system of differential equations.

$$\dot{x} = -3x + 2y,$$

$$\dot{y} = 3x^2 + 3y.$$

- (10 Points) Show that this system has a conserved quantity  $E$  and determine  $E$ . Recall, a quantity  $E : \mathbb{R}^2 \mapsto \mathbb{R}$  is conserved if  $E$  is constant along solution trajectories.
- (5 Points) Calculate an explicit formula for the nullclines and fixed points for this problem.
- (5 Points) Determine an explicit formula for any heteroclinic or homoclinic orbits in this problem.
- (5 Points) Sketch a phase portrait for this problem.

$$\bullet \quad \frac{dE}{dt} = \frac{\partial E}{\partial x} \dot{x} + \frac{\partial E}{\partial y} \dot{y}$$

This system is conservative if

$$\dot{x} = -\frac{\partial E}{\partial y}, \quad \dot{y} = \frac{\partial E}{\partial x}$$

$$\Rightarrow \frac{\partial \dot{x}}{\partial x} = -\frac{\partial \dot{y}}{\partial y}$$

$$\Rightarrow -3 = -3 \checkmark$$

The energy is:

$$E = 3xy - y^2 + x^3$$

• The nullclines and fixed points are

$$-y = \frac{3}{2}x$$

$$-y = -x^2$$

$$(0,0), \left(-\frac{3}{2}, -\frac{9}{4}\right)$$

• The homoclinic orbit satisfies

$$0 = 3xy - y^2 + x^3$$

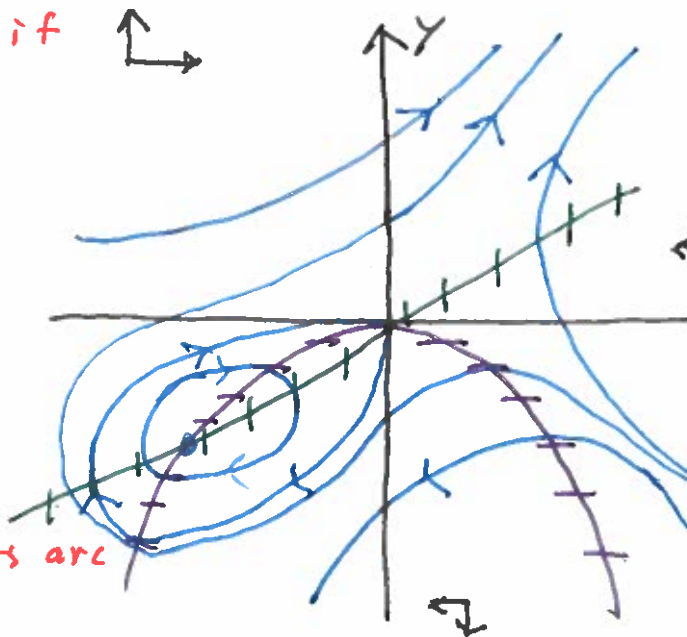

(b) Consider the following system of differential equations in polar coordinates:

$$\begin{aligned}\dot{r} &= r(1 - r^2), \\ \dot{\theta} &= a + \sin(\theta),\end{aligned}$$

where  $a \geq 0$  is a constant.

- (15 Points) Sketch phase portraits of this system for the cases  $a = 0$ ,  $a = 1$ , and  $a > 1$ . **Note:** All phase portraits must be drawn in Cartesian coordinates.
- (10 Points) Show that when  $a > 1$  the period  $T$  of any periodic orbit satisfies

$$\frac{2\pi}{a+1} < T < \frac{2\pi}{a-1}.$$

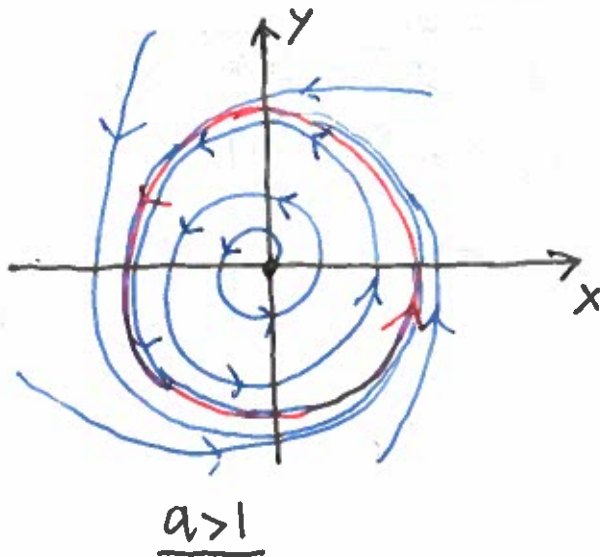
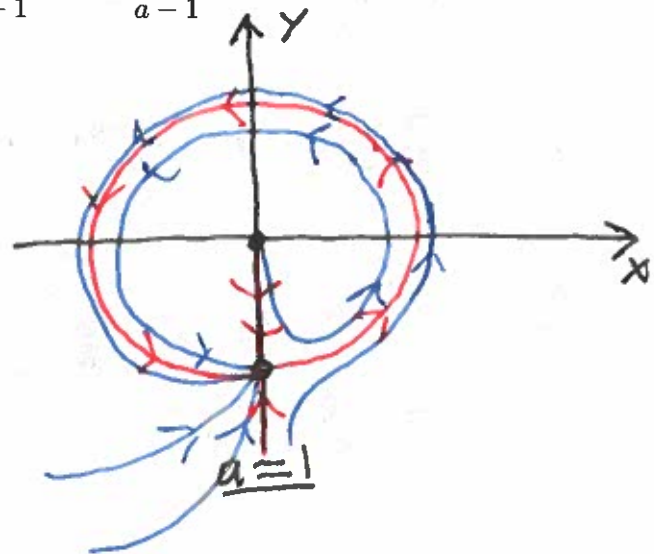
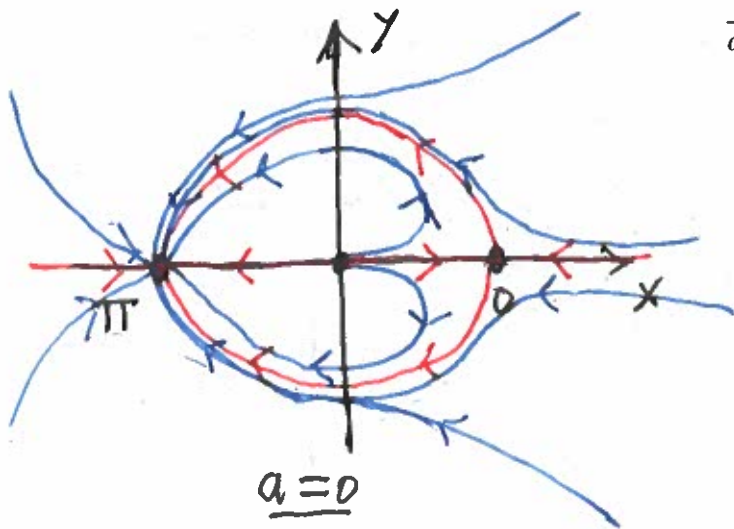

$$\begin{aligned}\frac{d\theta}{dt} &= a + \sin\theta \\ \Rightarrow T &= \int_0^{2\pi} \frac{1}{a + \sin\theta} d\theta\end{aligned}$$

Therefore, if  $a > 1$  it follows that

$$\int_0^{2\pi} \frac{1}{a+1} < T < \int_0^{2\pi} \frac{1}{a-1} d\theta$$

$$\Rightarrow \frac{2\pi}{a+1} < T < \frac{2\pi}{a-1}$$

6. (20 points) Do either part (a) or part (b). Circle which problem you want graded.

- (a) Suppose  $(X, \|\cdot\|)$  is a normed linear space,  $T : X \mapsto X$  is a bounded linear operator, and  $E \subset X$  is a Banach space with respect to the norm  $\|\cdot\|$ . Prove that if  $E$  is invariant under  $T$  then  $E$  is also invariant under  $\exp(T)$ . **Note:** To correctly solve this problem you must use the fact that  $E$  is a Banach space.

Let  $x \in E$ . Define

$$x_n = \left( I + A + \frac{A^2}{2} + \dots + \frac{A^n}{n!} \right) x.$$

Since  $E$  is invariant  $x_n \in E$ . Moreover,

$$x_n \rightarrow \exp(x).$$

By completeness of  $E$  it thus follows that  $\exp(x) \in E$ .

(b) Let  $A, B$  be  $n \times n$  real matrices that satisfy  $[A, B] = 0$ .

- (10 Points) Let  $F = B \exp(tA)$  and  $G = \exp(tA)B$ . Show that  $F$  and  $G$  satisfy the same initial value problem

$$\begin{aligned}\dot{\phi} &= A\phi, \\ \phi(0) &= B,\end{aligned}$$

and thus prove for all  $t$  that  $B \exp(tA) = \exp(tA)B$ .

- (10 Points) Let  $\Phi(t) = \exp(tA) \exp(tB)$ . Derive an initial value problem satisfied by  $\Phi$ . Show that  $\exp(t(A+B))$  satisfies the same initial value problem and thus prove that  $\exp(tA) \exp(tB) = \exp(t(A+B))$ .

$$\begin{aligned}\dot{F} &= B \cdot A \exp(tA) = A B \exp(tA) = A F \\ \dot{G} &= A \exp(tA) B = A G.\end{aligned}$$

By existence and uniqueness since  $F(0) = G(0) = B$  it follows that for all  $t$

$$B \exp(tA) = \exp(tA) B.$$

$$\begin{aligned}\dot{\Phi} &= A \exp(tA) \exp(tB) + \exp(tA) B \exp(tB) \\ &= A \exp(tA) \exp(tB) + B \exp(tA) \exp(tB) \\ &= (A+B) \exp(tA) \exp(tB) \\ &= (A+B) \Phi\end{aligned}$$

$$\frac{d}{dt} \exp(t(A+B)) = (A+B) \exp(t(A+B))$$

By existence and uniqueness it follows that

$$\exp(tA) \exp(tB) = \exp(t(A+B)).$$



7. (20 points) Consider the following linear system of differential equations:

$$\dot{x} = z,$$

$$\dot{y} = x - y,$$

$$\dot{z} = -x.$$

- (10 Points) Find the stable, unstable, and center subspaces of this system.

$$\dot{\vec{x}} = A\vec{x}, \text{ where}$$

$$A = \begin{bmatrix} 0 & 0 & 1 \\ 1 & -1 & 0 \\ -1 & 0 & 0 \end{bmatrix}$$

$$\det(\lambda I - A) = \det \begin{pmatrix} \lambda & 0 & -1 \\ -1 & \lambda+1 & 0 \\ 1 & 0 & \lambda \end{pmatrix} = -(\lambda+1) \det \begin{pmatrix} \lambda & -1 \\ 1 & \lambda \end{pmatrix} \\ = -(\lambda+1)(\lambda^2+1)$$

The eigenvalues are  $\lambda = -1, \lambda = \pm i$

$$\underline{\lambda = -1} \\ \lambda I - A = \begin{bmatrix} -1 & 0 & -1 \\ -1 & 0 & 0 \\ 1 & 0 & -1 \end{bmatrix} \Rightarrow \vec{v}_1 = \begin{bmatrix} 0 \\ 1 \\ 0 \end{bmatrix}$$

$$\underline{\lambda = i} \\ \begin{bmatrix} i & 0 & -1 \\ -1 & i+1 & 0 \\ 1 & 0 & i \end{bmatrix} \Rightarrow \begin{bmatrix} i & 0 & -1 \\ 0 & i+1 & i \\ 0 & 0 & 0 \end{bmatrix}$$

$$\Rightarrow \vec{v}_2 = \begin{bmatrix} z/i \\ -iz/i+1 \\ z \end{bmatrix} = z \begin{bmatrix} -i \\ -i(i-1) \\ 1 \end{bmatrix} = z \begin{bmatrix} -i \\ 1+i \\ 1 \end{bmatrix}$$

- (5 Points) Is this system stable?

- (5 Points) Roughly sketch a three-dimensional phase portrait of this system. In particular, be sure to sketch the stable, unstable, and center subspaces, the dynamics on these subspaces and enough solution trajectories to illustrate the qualitative behavior of the system.

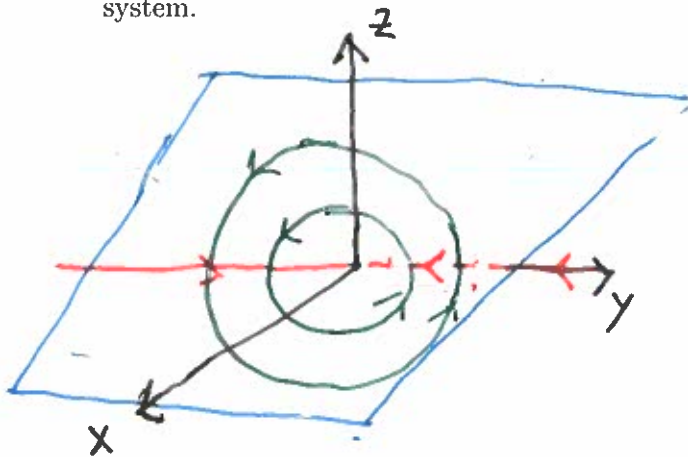

$$E_s = \text{span} \left\{ \begin{bmatrix} 0 \\ 1 \\ 0 \end{bmatrix} \right\}$$

$$E_c = \text{span} \left\{ \begin{bmatrix} 0 \\ 1/2 \\ 1 \end{bmatrix}, \begin{bmatrix} -1 \\ 1/2 \\ 0 \end{bmatrix} \right\}$$

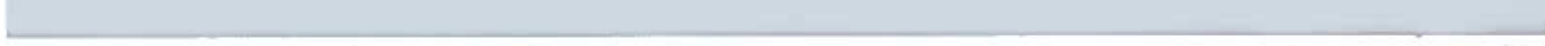

The first part of the document discusses the importance of maintaining accurate records of all transactions and activities. It emphasizes that this is crucial for ensuring the integrity and transparency of the organization's operations.

In the second section, the author outlines the various methods used to collect and analyze data. This includes both qualitative and quantitative approaches, as well as the use of advanced statistical tools and software.

The third section focuses on the results of the research. It provides a detailed breakdown of the findings, highlighting key trends and patterns that emerged from the data.

Finally, the document concludes with a series of recommendations and suggestions for future research. These are based on the insights gained from the current study and aim to guide further exploration in this field.

