



PHY 711 Classical Mechanics and Mathematical Methods

10-10:50 AM MWF in Olin 103

Notes for Lecture 13 – Chap. 1 (F &W)

Scattering analysis

1. Review of particle interactions
2. Two particles interacting with a central potential
3. Conservation of energy and angular momentum
4. Definition of differential scattering cross section
5. Notion of “impact” parameter and its role in calculating the differential cross section.

Course schedule

(Preliminary schedule -- subject to frequent adjustment.)

	Date	F&W	Topic	HW
1	Mon, 8/28/2023		Introduction and overview	#1
2	Wed, 8/30/2023	Chap. 3(17)	Calculus of variation	#2
3	Fri, 9/01/2023	Chap. 3(17)	Calculus of variation	#3
4	Mon, 9/04/2023	Chap. 3	Lagrangian equations of motion	#4
5	Wed, 9/06/2023	Chap. 3 & 6	Lagrangian equations of motion	#5
6	Fri, 9/08/2023	Chap. 3 & 6	Lagrangian equations of motion	#6
7	Mon, 9/11/2023	Chap. 3 & 6	Lagrangian to Hamiltonian formalism	#7
8	Wed, 9/13/2023	Chap. 3 & 6	Phase space	
9	Fri, 9/15/2023	Chap. 3 & 6	Canonical Transformations	#8
10	Mon, 9/18/2023	Chap. 5	Dynamics of rigid bodies	#9
11	Wed, 9/20/2023	Chap. 5	Dynamics of rigid bodies	#10
12	Fri, 9/22/2023	Chap. 5	Dynamics of rigid bodies	#11
13	Mon, 9/25/2023	Chap. 1	Scattering analysis	#12
14	Wed, 9/27/2023			
15	Fri, 9/29/2023			

PHY 711 – Assignment #1 2

Assigned: 09/25/2023 Due: 10/02/2023

1. Consider a particle of mass m moving in the vicinity of another particle of mass M , initially at rest, where $m \ll M$. The particles interact with a conservative central potential of the form

$$V(r) = V_0 \left(\left(\frac{r_0}{r} \right)^2 - \left(\frac{r_0}{r} \right) \right),$$

where r denotes the magnitude of the particle separation and V_0 and r_0 denote energy and length constants, respectively. The total energy of the system E is constant and $E = V_0$.

- (a) First consider the case where the impact parameter $b = 0$. Find the distance of closest approach of the particles.
- (b) Now consider the case where the impact parameter $b = r_0$. Find the distance of closest approach of the particles.

Introduction to the analysis of the energy and forces between two particles –

This treatment can be formulated with Lagrangians and Hamiltonians, but we will directly use the Newtonian approach for now..



First consider fundamental picture of particle interactions
Classical mechanics of a conservative 2-particle system.

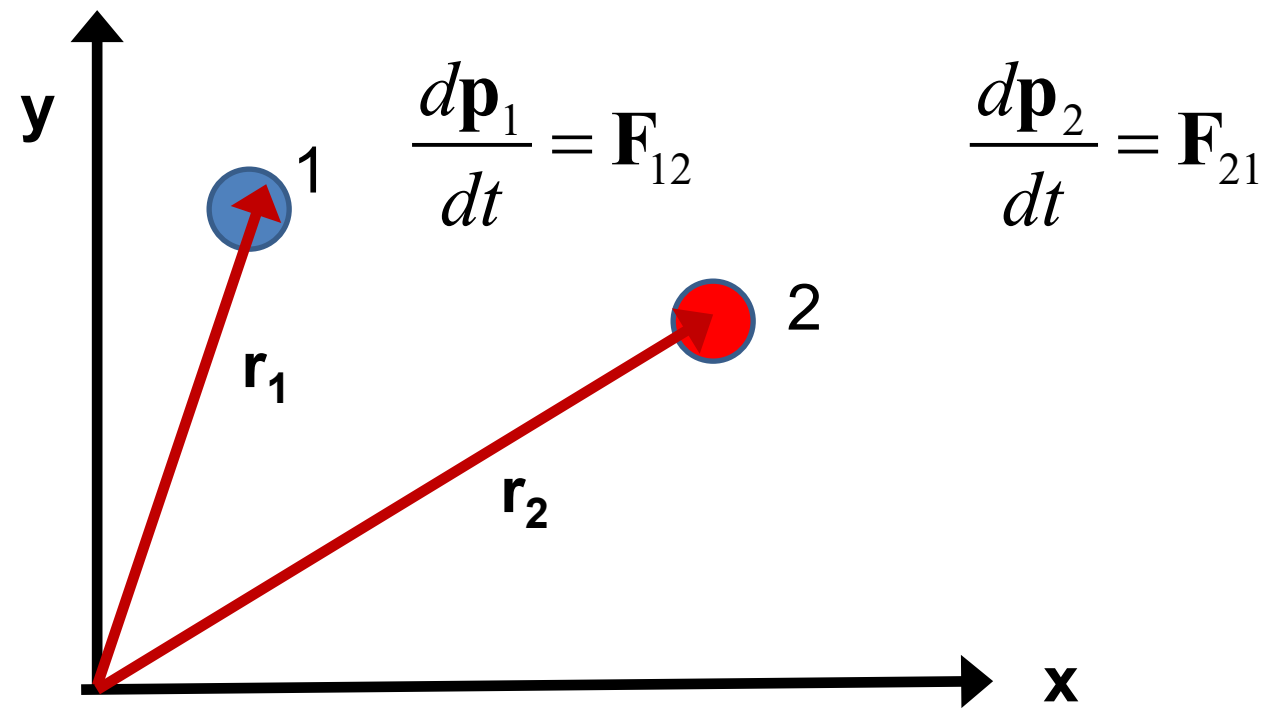

$$\mathbf{F}_{12} = -\nabla_1 V(\mathbf{r}_1 - \mathbf{r}_2) \quad \Rightarrow \quad E = \frac{1}{2} m_1 v_1^2 + \frac{1}{2} m_2 v_2^2 + V(\mathbf{r}_1 - \mathbf{r}_2)$$

For this discussion, we will assume that $V(\mathbf{r})=V(r)$ (a central potential).



Energy is conserved:
$$E = \frac{1}{2}m_1v_1^2 + \frac{1}{2}m_2v_2^2 + V(\mathbf{r}_1 - \mathbf{r}_2)$$

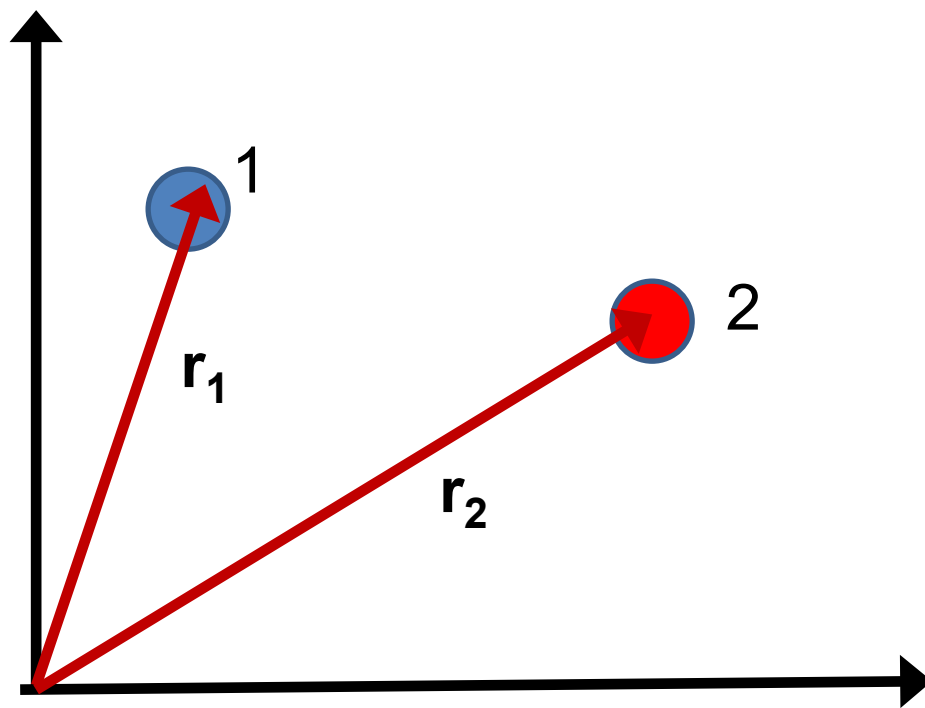

For a central potential $V(\mathbf{r})=V(r)$, angular momentum is conserved. For the moment we also make the simplifying assumption that $m_2 \gg m_1$ so that particle 1 dominates the motion.



Typical two-particle interactions –

Central potential: $V(\mathbf{r}_1 - \mathbf{r}_2) = V(|\mathbf{r}_1 - \mathbf{r}_2|) \equiv V(r)$

Hard sphere:
$$V(r) = \begin{cases} \infty & r \leq a \\ 0 & r > a \end{cases}$$

Coulomb or gravitational:
$$V(r) = \frac{K}{r}$$

Lennard-Jones:
$$V(r) = \frac{A}{r^{12}} - \frac{B}{r^6}$$

More details of two particle interaction potentials

Central potential: $V(\mathbf{r}_1 - \mathbf{r}_2) = V(|\mathbf{r}_1 - \mathbf{r}_2|) \equiv V(r)$

This means that the interaction only depends on the distance between the particles and not on the angle between them. This would typically be true of the particles are infinitesimal points without any internal structure such as two infinitesimal charged particles or two infinitesimal masses separated by a distance r :

$$V(r) = \frac{K}{r}$$

Example – Interaction between a proton and an electron. Note we are treating the interactions with classical mechanics; in some cases, quantum effects are non-trivial.

Other examples of central potentials --

Example

Hard sphere:

$$V(r) = \begin{cases} \infty & r \leq a \\ 0 & r > a \end{cases}$$

Two marbles

Lennard-Jones:

$$V(r) = \frac{A}{r^{12}} - \frac{B}{r^6}$$

Two Ar atoms

Note – not all systems are described by this form. Some counter examples:

1. Molecules (internal degrees of freedom)
2. Systems with more than two particles such as crystals

Representative plot of $V(r)$

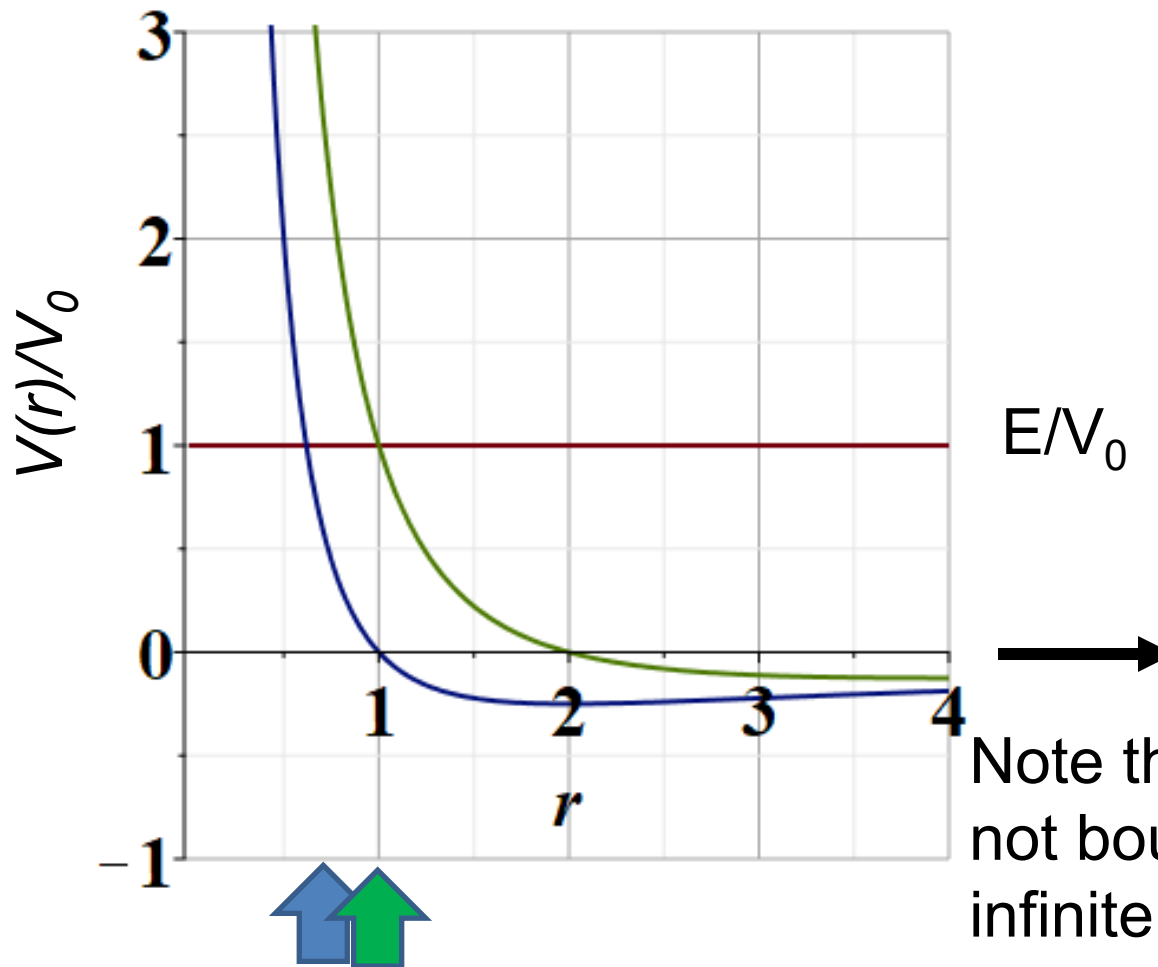

Distances of closest approach

Some more details --

Here we are assuming that the target particle is stationary and $m_1 \equiv m$.

The origin of our coordinate system is taken at the position of the target particle.

Conservation of energy:

$$E = \frac{1}{2} m \left(\frac{d\mathbf{r}}{dt} \right)^2 + V(r)$$
$$= \frac{1}{2} m \left(\left(\frac{dr}{dt} \right)^2 + r^2 \left(\frac{d\theta}{dt} \right)^2 \right) + V(r)$$

Conservation of angular momentum:

$$|\mathbf{L}| = L = mr^2 \frac{d\theta}{dt}$$

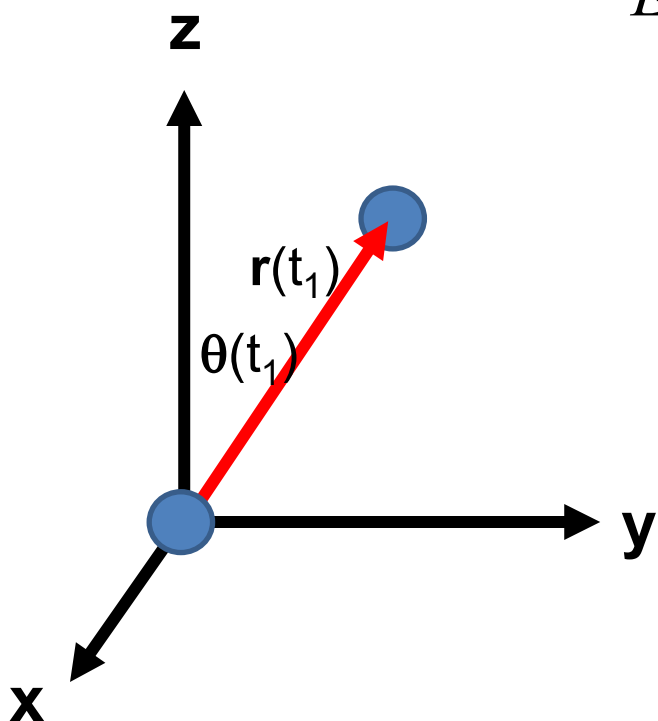

Comments continued --

Conservation of energy:

$$\begin{aligned} E &= \frac{1}{2} m \left(\frac{d\mathbf{r}}{dt} \right)^2 + V(r) \\ &= \frac{1}{2} m \left(\left(\frac{dr}{dt} \right)^2 + r^2 \left(\frac{d\theta}{dt} \right)^2 \right) + V(r) \\ &= \frac{1}{2} m \left(\frac{dr}{dt} \right)^2 + \boxed{\frac{L^2}{2mr^2} + V(r)} \end{aligned}$$

Conservation of angular momentum:

$$L = mr^2 \frac{d\theta}{dt}$$

$$V_{\text{eff}}(r)$$

Also note that when $r \rightarrow \infty$, $V(r) \rightarrow 0$

$$\mathbf{L} \equiv \mathbf{r} \times m \frac{d\mathbf{r}}{dt} \quad L = b\sqrt{2mE}$$

$$\text{For } r \rightarrow \infty, \quad \frac{d\mathbf{r}}{dt} \rightarrow v_\infty = \sqrt{\frac{2E}{m}}$$

$$E = \frac{1}{2} m \left(\frac{dr}{dt} \right)^2 + \frac{b^2 E}{r^2} + V(r)$$

What is the impact parameter?

Briefly, a convenient distance that depends on the conserved energy and angular momentum of the process.

Also note that when $r \rightarrow \infty$, $V(r) \rightarrow 0$

$$\mathbf{L} \equiv \mathbf{r} \times m \frac{d\mathbf{r}}{dt} \quad L = b\sqrt{2mE}$$

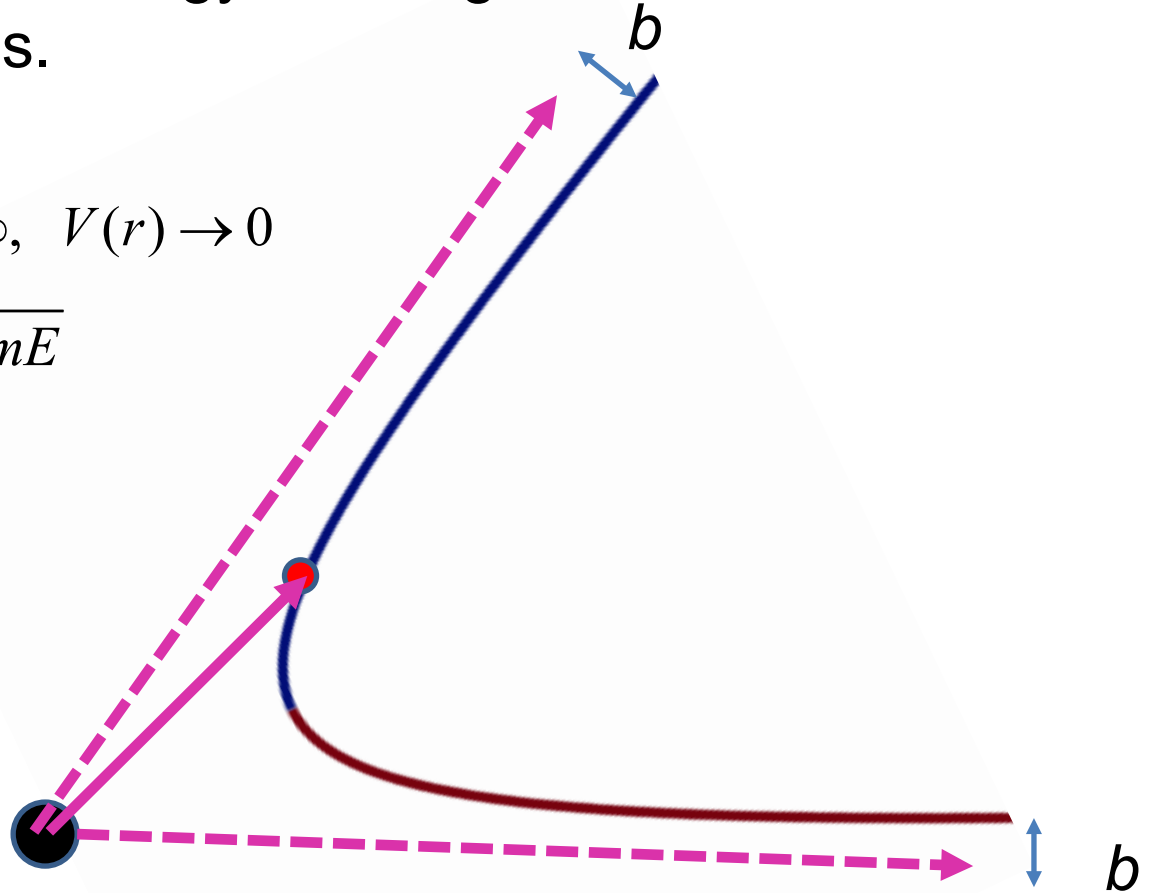



Which of the following are true for a particle moving in a central potential field:

- a. The particle moves in a plane.
- b. For any interparticle, potential the trajectory can be determined/calculated.
- c. Only for a few special interparticle potential forms can the trajectory be determined.

Why should we care about this?

- a. We shouldn't really care.
- b. It is only of academic interest
- c. It is of academic interest but can be measured.
- d. Many experiments can be analyzed in terms of the particle trajectory.

Scattering theory:

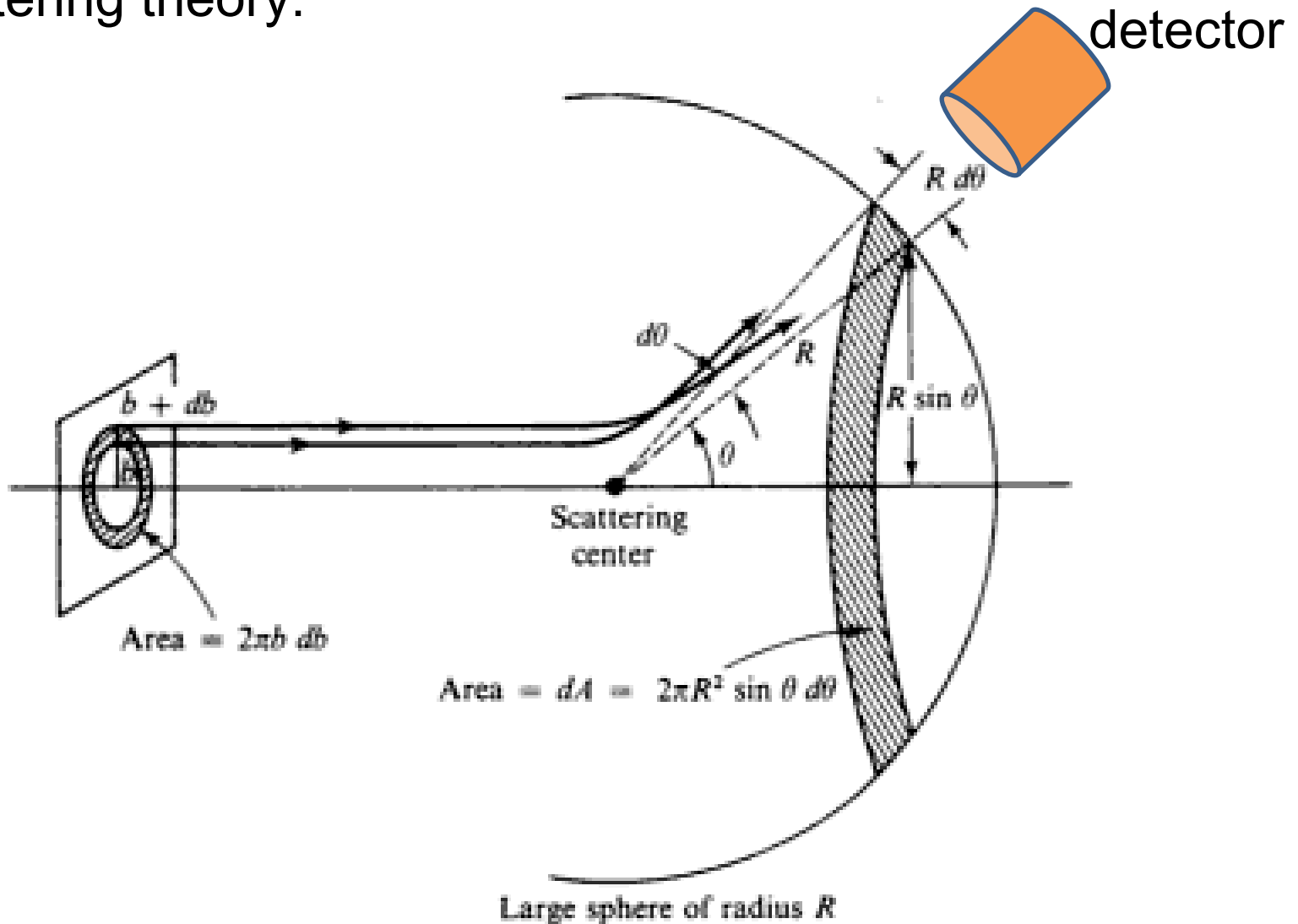

Figure 5.5 The scattering problem and relation of cross section to impact parameter.

Scattering theory:

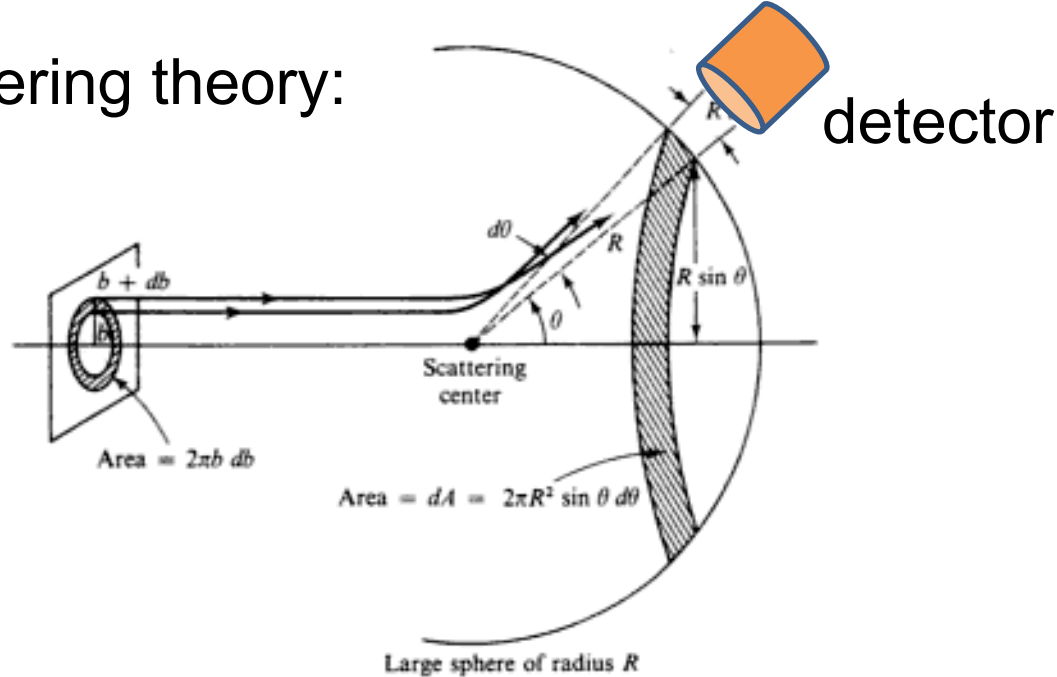

Figure 5.5 The scattering problem and relation of cross section to impact parameter.

Some reasons that scattering theory is useful:

1. It allows comparison between measurement and theory
2. The analysis depends on knowledge of the scattering particles when they are far apart
3. The scattering results depend on the interparticle interactions

Example: Diagram of Rutherford scattering experiment

<http://hyperphysics.phy-astr.gsu.edu/hbase/rutsca.html>

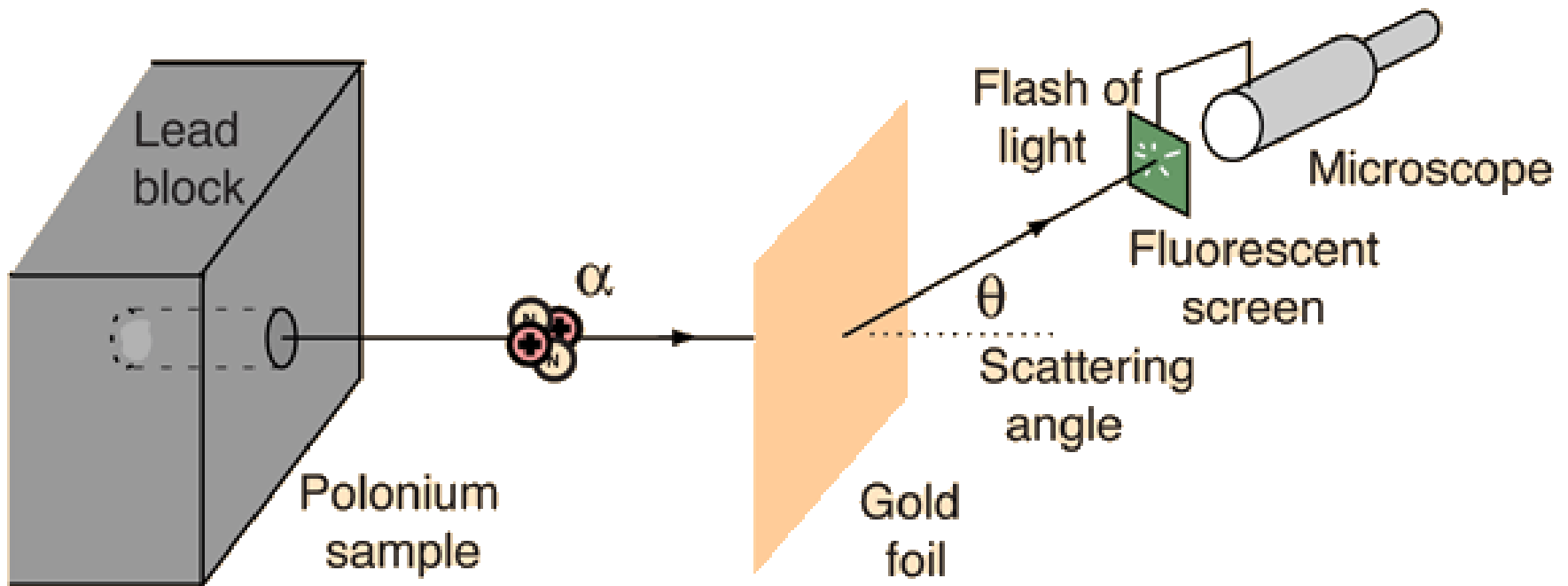

Graph of data from scattering experiment

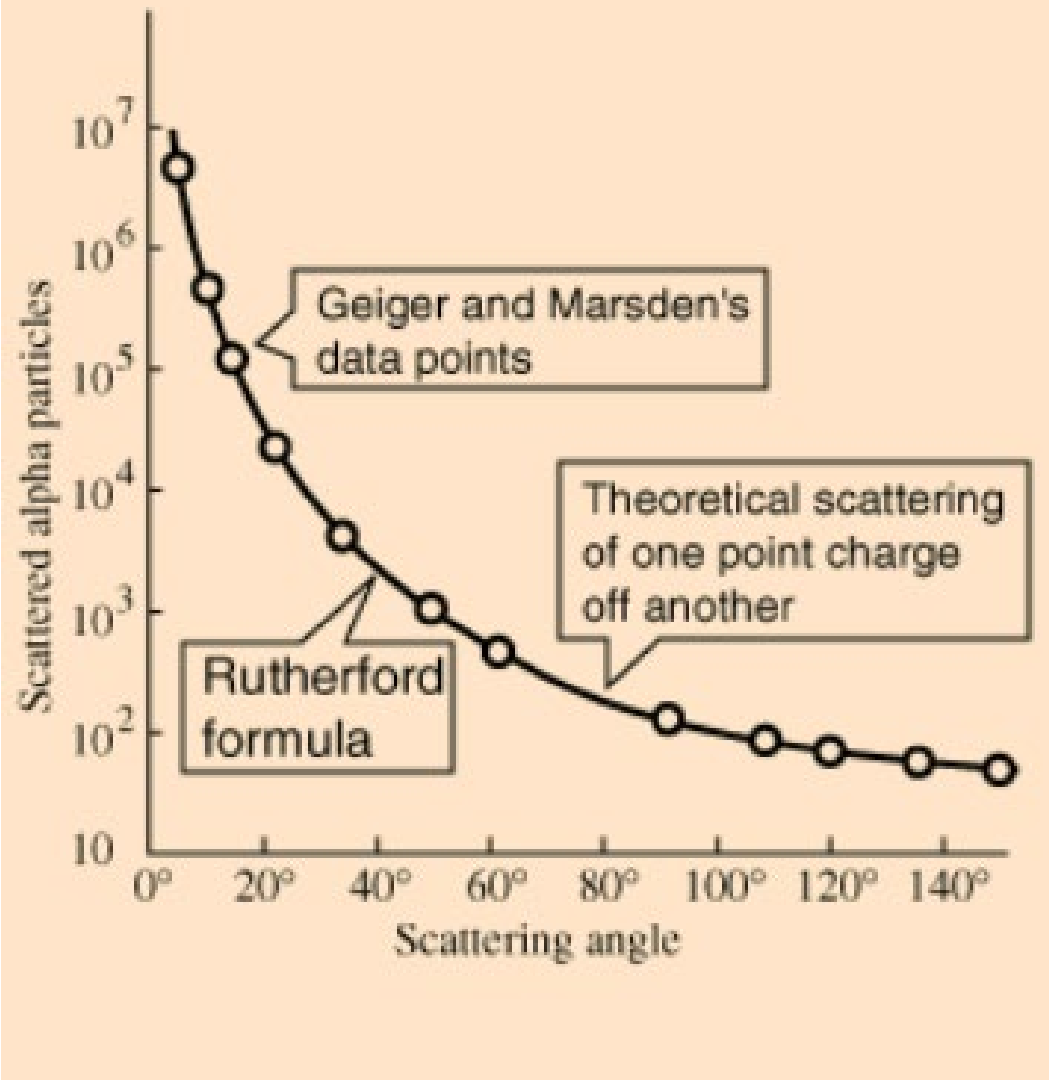

From website: <http://hyperphysics.phy-astr.gsu.edu/hbase/Nuclear/rutsca2.html>

Standardization of scattering experiments --

Differential cross section

$$\left(\frac{d\sigma}{d\Omega} \right) = \frac{\text{Number of detected particles at } \theta \text{ per target particle}}{\text{Number of incident particles per unit area}}$$

= Area of incident beam that is scattered into detector
at angle θ

Impact parameter: b

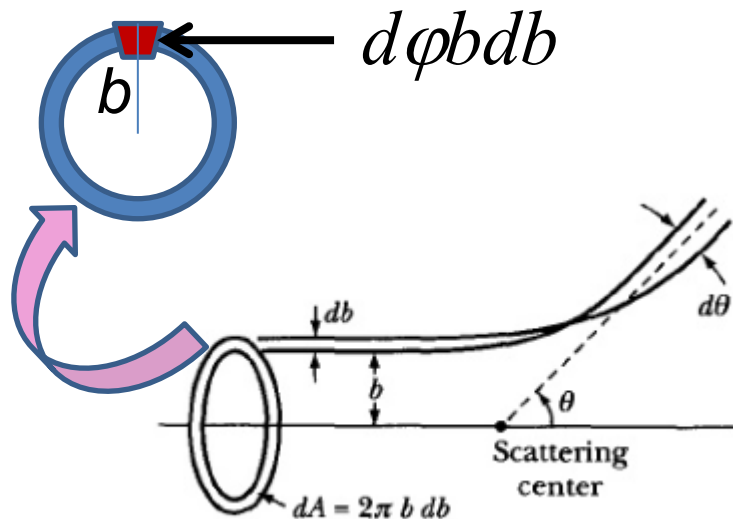

$$\left(\frac{d\sigma}{d\Omega} \right) = \frac{d\phi b db}{d\phi \sin\theta d\theta} = \frac{b}{\sin\theta} \left| \frac{db}{d\theta} \right|$$

Figure from Marion & Thorton, Classical Dynamics

Note: The notion of cross section is common to many areas of physics including classical mechanics, quantum mechanics, optics, etc. Only in the **classical mechanics** can we calculate it from a knowledge of the particle trajectory as it relates to the scattering geometry.

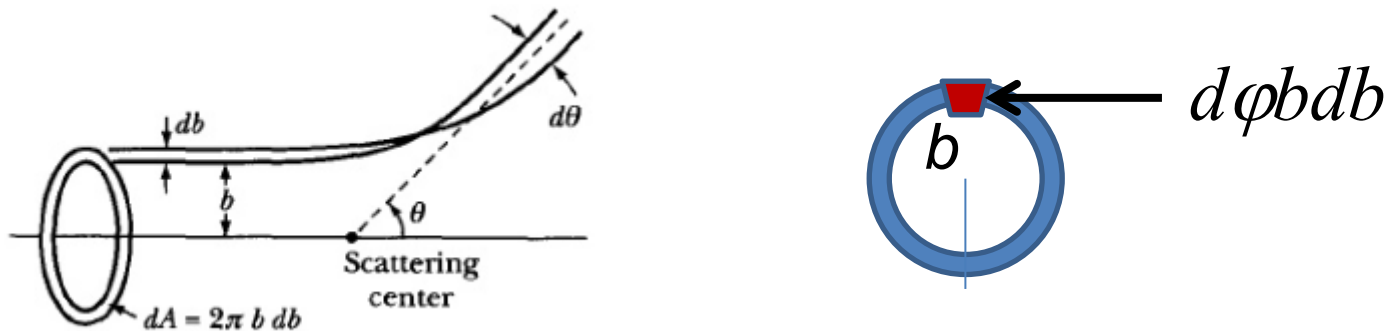

Figure from Marion & Thorton, Classical Dynamics

$$\left(\frac{d\sigma}{d\Omega} \right) = \frac{d\phi b db}{d\phi \sin\theta d\theta} = \frac{b}{\sin\theta} \left| \frac{db}{d\theta} \right|$$

Note: We are assuming that the process is isotropic in ϕ



Simple example – collision of hard spheres having mutual radius D ; very large target mass

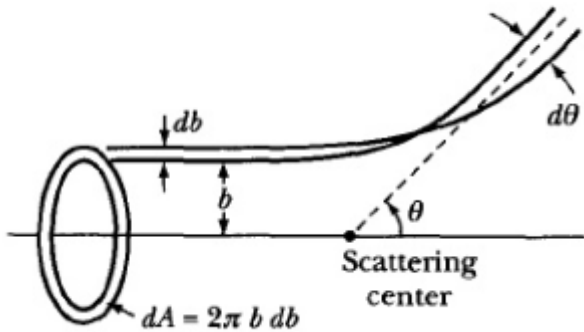

$$\left(\frac{d\sigma}{d\Omega} \right) = \frac{b}{\sin\theta} \left| \frac{db}{d\theta} \right|$$

Microscopic view:

$$b(\theta) = ?$$

$$b(\theta) = D \sin\left(\frac{\pi}{2} - \frac{\theta}{2}\right)$$

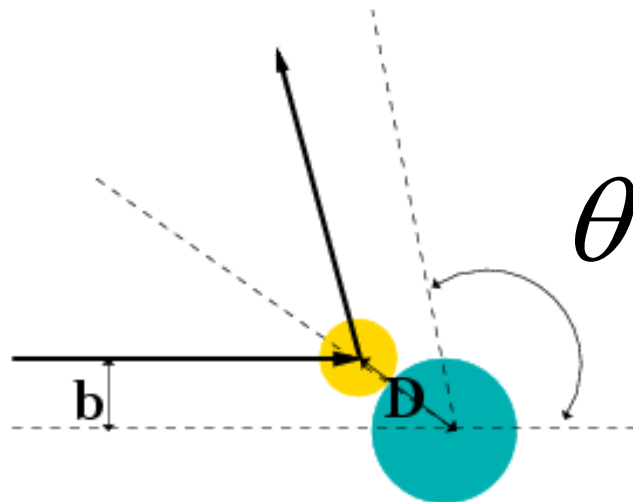

$$\left(\frac{d\sigma}{d\Omega} \right) = \frac{D^2}{4}$$

Simple example – collision of hard spheres -- continued

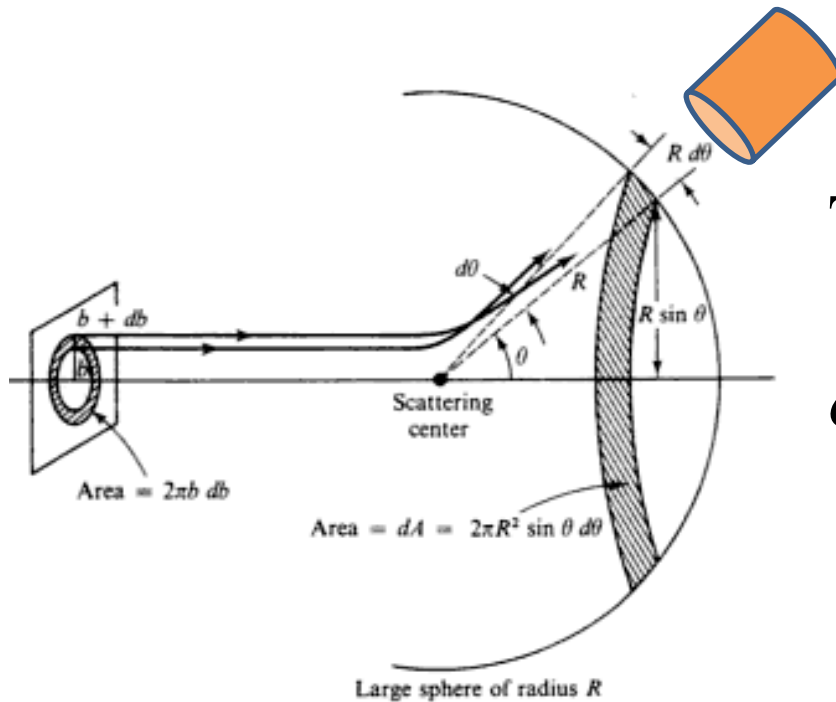

Total scattering cross section:

$$\sigma = \int \left(\frac{d\sigma}{d\Omega} \right) d\Omega$$

Hard sphere:

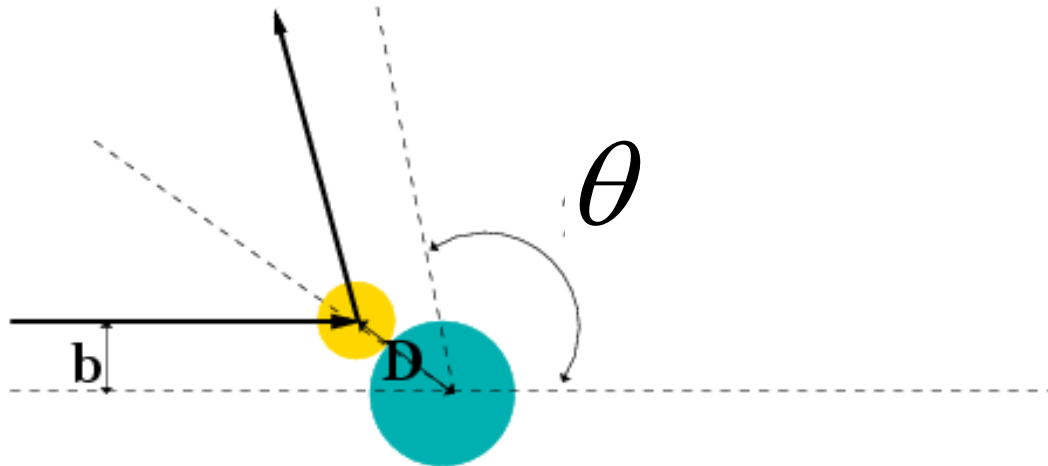

$$\left(\frac{d\sigma}{d\Omega} \right) = \frac{D^2}{4}$$

$$\sigma = \pi D^2$$



More details of hard sphere scattering –

Hidden in the analysis are assumptions about the scattering process such as:

- No external forces → linear momentum is conserved
- No dissipative phenomena → energy is conserved
- No torque on the system → angular momentum is conserved
- Target particle is much more massive than scattering particle
- Other assumptions??

Note that for quantum mechanical hard spheres at low energy the total cross section is 4 times as large.